

# DRAIN CLEANING

## K-400 Drum Machine



Model K-400 with AUTOFEED®

### For 1½" (30 mm) to 4" (110 mm) Drain Lines

The Model K-400 offers several unique, user-friendly features to make the toughest drain cleaning jobs easier and hassle-free. Designed with a sleek profile, the Model K-400 is a great fit for drain cleaners, service plumbers, facility and institutional maintenance departments and property management companies.

- ⅜" (10 mm) cable best for 1½" (40 mm) to 3" (75 mm) lines.
- ½" (12 mm) cable best for 3" (50 mm) to 4" (110 mm) lines.
- Integrated Transport Cart – allows for easy movement to and from the job site. Heavy-duty, large wheels easily navigate over bumps and up stairs.
- Integrated Telescoping Handle – provides high-handle height during transport.
- Cable Control System – causes the drum to stop spinning when the blade becomes lodged in a blockage, limits potential for cable to flip-over in the drum and helps to indicate to operator when blockages are encountered.
- "Solid Core" Cable – uses tough ⅜" (10 mm) or ½" (12 mm) Integral Wound (IW) solid core cable that is rugged and kink resistant.
- AUTOFEED – offered as an accessory, this patented, automatic cable feed powers cable in and out of the drum. Reverse the direction of the AUTOFEED and the cable feeds back into the drum.

### Specifications

- Drum Capacity: 100' (30,5 m) of ⅜" (10 mm) Diameter Cable or 75' (22,5 m) of ½" (12 mm) Diameter Cable.
- Motor: 380 W, 230 V motor spins cable at 165 RPM.
- Weight (Machine Only): 45 lbs. (20,4 kg).
- Dimensions: Length 21" (53 cm) 24" (61 cm) with AUTOFEED, Height 23" (58,5 cm) Width 17" (43,2 cm).

All Model K-400 machines are supplied with RIDGID® drain cleaning gloves, operator's manual and instructional video.

Catalog No.	Model No.	Description	Weight	
			lb.	kg
27028	K-400 w/ C-32 IW	K-400 Machine w/RIDGID Drain Cleaning Gloves – C-32 IW ⅜" (10 mm) x 75' (23 m) Solid Core (Integral Wound) Cable – T-260 Tool Set Includes: – T-202 Bulb Auger – T-205 "C" Cutter – T-211 Spade Cutter – A-13 Pin Key	68	31
28098	K-400 AF w/C-32 IW	K-400 Machine w/RIDGID Drain Cleaning Gloves – AUTOFEED – C-32 IW ⅜" (10 mm) x 75' (23 m) Solid Core (Integral Wound) Cable – T-260 Tool Set	79	36
27033	K-400 w/ C-45 IW	K-400 Machine w/RIDGID Drain Cleaning Gloves – C-45 IW ½" (12 mm) x 75' (23 m) Solid Core (Integral Wound) Cable – T-260 Tool Set	81	37
28103	K-400 AF w/C-45 IW	K-400 Machine w/RIDGID Drain Cleaning Gloves – AUTOFEED – C-45 IW ½" (12 mm) x 75' (23 m) Solid Core (Integral Wound) Cable – T-260 Tool Set	93	42

# DRAIN CLEANING

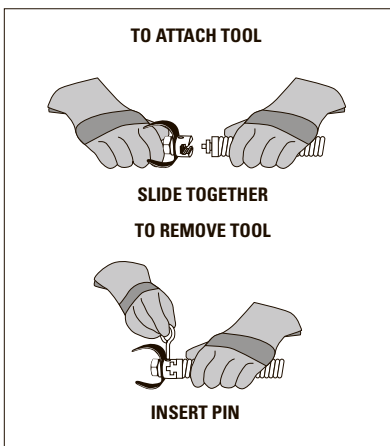

For C-4, C-6, C-6IC, C-7, C-8, C-9, C-10, C-11, C-12, C-14, C-15, C-31, C-32, C-33, C-44, C-45, and C-46 & all IW Cables.

## IW (Integral Wound) Solid Core Cables

		Catalog No.	Model No.	Description	Weight	
					lb.	kg
3/8" (10 mm)		87577	C-31IW	50' (15 m) IW Cable	18	8,2
		87582	C-32IW	75' (23 m) IW Cable	26	11,8
		87587	C-33IW	100' (30 m) IW Cable	34	15,4
		91037	-	Repair End for 3/8" (10 mm) IW Cable	0.5	0,2
1/2" (12 mm)		87592	C-44IW	50' (15 m) IW Cable	27	12,2
		87597	C-45IW	75' (23 m) IW Cable	39	17,7
		91042	-	Repair End for 1/2" (12 mm) IW Cable	0.6	0,3

## Tools – Fits C-31IW, C-32IW, C-33IW, C-44IW and C-45IW

	Catalog No.	Model No.	Description	Replacement Blade(s)
	62990	T-201	Straight Auger, 5' (125 mm) Long	—
	62995	T-202	Bulb Auger, 1 1/2" (30 mm) O.D.	—
	63000	T-203	Bulb Auger 7/8" (22 mm) O.D.	—
	63005	T-205	"C" Cutter, 1 3/8" (35 mm)	97835
	63010	T-206	Funnel Auger, 3" (80 mm) Long	—
	63030	T-207	Spiral Cutter, 1 1/4" (32 mm)	97840
	63020	T-208	Spiral Cutter, 1 1/2" (40 mm)	97895
	63025	T-209	Spiral Cutter, 2" (50 mm)	97900
	63030	T-210	Spade Cutter, 1" (25 mm)	97905
	63035	T-211	Spade Cutter, 1 3/8" (35 mm)	97825
	63040	T-212	Spade Cutter, 1 3/4" (45 mm)	92850
	63045	T-213	4-Blade Cutter, 1" (25 mm)	97795
	63050	T-214	4-Blade Cutter, 1 3/8" (35 mm)	97910
	63055	T-215	4-Blade Cutter, 1 3/4" (45 mm)	97915
	63060	T-216	Chain Knocker, 2" (50 mm)	98000
	63065	T-217	Drop Head, 4" (110 mm) Long	—
	49002	T-260	Tool Set (3/8" (10 mm)- K-400) Includes: – T-202 Bulb Auger – T-205 "C" Cutter – T-211 Spade Cutter – A-13 Pin Key	—

## Accessories

	Catalog No.	Model No.	Description	Weight	
				lb.	kg
	41937	-	RIDGID Drain Cleaning Gloves, Leather	1/2	0,2
	70032	-	RIDGID PVC Drain Cleaning Gloves	1/2	0,2
	59230	A-13	Pin Key for 3/8" and 1/2" Cable	-	-
	26773	-	K-400 AUTOFEED Assembly	2	0,9
	27048	-	K-400 Drum Assembly	10	4,5
	92607	-	3/8" x 1/2" Tool Adaptor	1/2	0,2
	92682	-	3/8" x 1/2" Drop Head Adaptor	1/2	0,2
	92687	-	Coupling 1/2" Drop Head Tool	1/2	0,2
	26778	-	Guide Hose	2	0,9
	51317	C-9	Trap Leader	5	2,2

# DRAIN CLEANING

## K-3800 Drum Machine







### For 3/4" (20 mm) to 4" (110 mm) Drain Lines

- A powerful, easy to transport, versatile machine for cleaning indoor drains. Requires minimal setup to clean sink lines, floor drains and roof vents.
- Rugged, corrosion-resistant molded cable drum won't dent or rust. The drum tilt adjusts for proper cable feed angle. Inner-drum guards against cable flip-over inside the drum.
- Cable drum's quick-release and built-in hand-holds allow easy cable change and transport.
- Maximum drum capacity is 100' (30,5 m) of 3/8" (10 mm) or 90' (27 m) of 1/2" (12 mm) continuous length cable:
  - 3/8" (10 mm) cable best for 1 1/2" (40 mm) to 3" (75 mm) lines up to 100' (30,5 m).
  - 1/2" (12 mm) cable best for 2" (50 mm) to 4" (110 mm) lines up to 90' (27 m).
- Optional sink drum holds up to 50' (15 m) of 5/16" (8 mm) or 1/4" (6 mm) cable.
  - Ideal for cleaning through 3/4" (20 mm) to 1 1/2" (40 mm) sink traps.
- Powerful 175 W Universal Motor spins cable at 240 RPM. When cable hits blockage, motor gears down automatically to deliver more power and enhance operator control.
- Tools connect to cable in seconds.
- Includes a heavy duty AUTOFEED® system (all modes except machine only).
- Includes RIDGID® leather drain cleaning gloves and operator's manual.

Catalog No.	Model No.	Description	Weight	
			lb.	kg
61502	K-3800	K-3800 Machine w/RIDGID Gloves	42	19,0
61482	K-3800 w/C-32	K-3800 Machine with: – AUTOFEED – C-32, 3/8" (10 mm) x 75' (23 m) Cable – T-202 Bulb Auger – T-205 "C" Cutter – T-211 Spade Cutter – A-13 Pin Key – RIDGID Leather Drain Cleaning Gloves	71	32,2
61487	K-3800 w/C-45	K-3800 Machine with: – AUTOFEED – C-45, 1/2" (12 mm) x 75' (23 m) Cable – T-102 Funnel Auger – T-142 Knife Blade Cutter – T-107 Spade Cutter – A-12 Pin Key – RIDGID Leather Drain Cleaning Gloves	83	37,7



### Accessories

	Catalog No.	Model No.	Description	Weight	
				lb.	kg
	55002	A-380	Standard Drum for 3/8" (10 mm), 1/2" (12 mm) Cable	12 1/2	5,6
	55007	A-381	Sink Drum for 5/16" (8 mm), 1/4" (6 mm) Cable	12 1/2	5,6
	55012	A-381-A	Sink Drum with 25' (7,6 m) x 5/16" (8 mm) IC Cable w/ Bulb Head	16 1/2	7,5
	41937	–	RIDGID Drain Cleaning Gloves, Leather	1/2	0,2
	70032	–	RIDGID Drain Cleaning Gloves, PVC	1/2	0,2
	59230	A-13	Pin Key For 3/8" (10 mm) Cable	1/2	0,2
	59225	A-12	Pin Key For 1/2" (12 mm) Cable	1/2	0,2
	55017	–	Transport Cart	18	8,2
	60087	A3800 PF	AUTOFEED® Assembly	7 3/8	3,3
	62412	–	Guide Hose Adapter for Sink Drum	3 1/2	1,6

# DRAIN CLEANING



## Inner Core (IC) Cables

Good flexibility and more cleaning power to the cable end.



		Catalog No.	Model No.	Description	Weight	
					lb.	kg
3/8" (10 mm)		37842	C-31	50' (15 m) IC Cable	18	8,2
		37847	C-32	75' (23 m) IC Cable	26	11,8
		37852	C-33	100' (30 m) IC Cable	34	15,4
		51752	T-122	Repair End	1	0,5
1/2" (12 mm)		37857	C-44	50' (15 m) IC Cable	27	12,2
		37862	C-45	75' (23 m) IC Cable	39	17,7
		37867	C-45HC	75' (23 m) Hollow Core Cable	38	17,2
		55467	C-46	90' (28 m) IC Cable	47	21,2
		59917	T-121	Repair End	3/4	0,8

## Integral Wound (IW) Cables

Wound tighter on the inner core creating a solid assembly.



















		Catalog No.	Model No.	Description	Weight	
					lb.	kg
3/8" (10 mm)		87577	C-31IW	50' (15 m) IW Cable	18	8,2
		87582	C-32IW	75' (23 m) IW Cable	26	11,8
		87587	C-33IW	100' (30 m) IW Cable	34	15,4
		91037	—	Repair End for IW Cable	1/2	0,2
1/2" (12 mm)		87592	C-44IW	50' (15 m) IW Cable	18	8,2
		87597	C-45IW	75' (23 m) IW Cable	26	11,8
		91042	—	Repair End for 1/2" (12 mm) IW Cable	3/4	0,3

## Sink Drum Cables

		Catalog No.	Model No.	Description	Weight	
					lb.	kg
1/8" (6 mm)		50652	S-2	25' (7,6 m) w/Funnel Auger	3 1/2	1,6
		50657	S-3	35' (10,7 m) w/Funnel Auger	5	2,2
5/16" (8 mm)		56782	C-11C	25' (7,6 m) Inner Core w/Bulb Auger	4	1,8
		56792	C-13IC	35' (10,7 m) with Bulb Auger	5 1/2	2,5
		56787	C-21C	25' (7,6 m) Inner Core w/Drop Head Auger	4	1,8
		56797	C-23IC	35' (10,7 m) with Drop Head Auger	5 1/2	2,5













## Tools Fit 3/8" (10 mm) IC, 3/8" (10 mm) IW and 1/2" (12 mm) IW Cables

C-31, C-32, C-33, C-31IW, C-32IW, C-33IW, C-44IW and C-45IW

	Catalog No.	Model No.	Description	Repl. Blade(s)
	62990	T-201	Straight Auger, 5" (125 mm) Long	—
	62995	T-202	Bulb Auger, 1 1/8" (29 mm) O.D.	—
	63000	T-203	Bulb Auger 7/8" (22 mm) O.D.	—
	54837	T-204	"C" Cutter, 1" (25 mm)	54832
	63005	T-205	"C" Cutter, 1 3/8" (35 mm)	97835
	63010	T-206	Funnel Auger, 3" (75 mm) Long	—
	63015	T-207	Spiral Cutter, 1 1/4" (32 mm)	97840
	63020	T-208	Spiral Cutter, 1 1/2" (40 mm)	97895
	63025	T-209	Spiral Cutter, 2" (50 mm)	97900
	63030	T-210	Spade Cutter, 1" (25 mm)	97905
	63035	T-211	Spade Cutter, 1 3/8" (35 mm)	97825
	63040	T-212	Spade Cutter, 1 3/4" (45 mm)	92850
	63045	T-213	4-Blade Cutter, 1" (25 mm)	97795
	63050	T-214	4-Blade Cutter, 1 3/8" (35 mm)	97910
	63055	T-215	4-Blade Cutter, 1 3/4" (45 mm)	97915
	63060	T-216	Chain Knocker, 2" (50 mm)	98000
	63065	T-217	Drop Head, 4" Long (110 mm)	—
	49002	T-260	Tool Set Includes: - T-202 Bulb Auger - T-205 "C" Cutter - T-211 Spade Cutter - A-13 Pin Key	—

## Tools Fit 1/2" (12 mm) IC Cables

C-44, C-45 and C-46

	Catalog No.	Model No.	Description	Repl. Blade(s)
	62850	T-101	Straight Auger	—
	62855	T-102	Funnel Auger	—
	62865	T-104	"H" Cutter, 2 1/2" (65 mm)	97800
	62870	T-105	Grease Cutter, 2 1/2" (65 mm)	97920
	62875	T-106	Grease Cutter 3 1/2" (87 mm)	97925
	62880	T-107	Spade Cutter, 1 3/4" (45 mm)	92850
	62930	T-112	4-Blade Cutter, 1 3/4" (45 mm)	97915
	62935	T-113	4-Blade Cutter, 3" (75 mm)	97910
	62940	T-114	Chain Knocker	97985
	54842	T-141	Knife Blade Cutter, 1 1/2" (40 mm)	54847
	54852	T-142	Knife Blade Cutter, 2 1/2" (65 mm)	97800
	54992	T-270	Tool Set: - T-102 Funnel Auger - T-142 Knife Blade Cutter - T-107 Spade Cutter - A-12 Pin Key	—
	92687		Drop Head Tool Adaptor 1/2" (12 mm)	—

### TO ATTACH TOOL

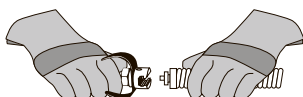

SLIDE TOGETHER

### TO REMOVE TOOL

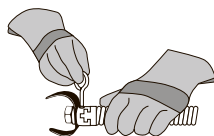

INSERT PIN

For C-4, C-6, C-6IC, C-7, C-8, C-9, C-10, C-11, C-12, C-14, C-15, C-31, C-32, C-33, C-44, C-45, and C-46 & all IW Cables.

# DRAIN CLEANING

## K-750 Drum Machine



### For 3" (75 mm) to 8" (200 mm) Drain/Sewer Lines

- Powerful, self-contained machine ideal for lateral lines. Easy to transport, minimal set-up – attach a tool and go.
- Autofeed advances, retrieves cable with a push of a lever, up to 20' (6 m) per minute.
- Versatile AUTOFEED™ control adjusts for either 5/8" (16 mm) or 3/4" (20 mm) cable with a twist of a screwdriver.
- Recommend 5/8" (16 mm) cable for 3" (75 mm) to 6" (150 mm) drain lines up to 150' (48 m).
- Recommend 3/4" (20 mm) cable for 4" (110 mm) to 8" (250 mm) drain lines up to 200' (62 m).
- Cable spins at 200 RPM.
- Tough, corrosion-resistant cable drum withstands harsh treatment and abuse. It will not dent or corrode and cleans easily.
- Drum holds 100' (30,5 m) of 3/4" (20 mm) or 125' (35 m) of 5/8" (16 mm) cable and is designed for quick, easy removal.
- Well-balanced design gives machine a lightweight "feel." Transport wheels ease loading into service truck/van.
- Equipped with 550 W induction motor.
- Includes RIDGID™ PVC drain cleaning gloves and operator's manual.

### Standard 3/4" (20 mm) Tool Set Includes:

- T-406 Spade Cutter.
- T-407 Retrieving Auger.
- T-411 2" (50 mm) Cutter.
- T-413 3" (75 mm) Cutter.
- T-414 4" (110 mm) Cutter.

### Standard 5/8" (16 mm) Tool Set Includes:

- T-403 3" (75 mm) P-Trap Cutter.
- T-407 Retrieving Auger.
- T-406 Spade Cutter.
- T-411 2" (50 mm) Cutter.
- T-413 3" (75 mm) Cutter.



Cable advance



Cable retract



Model K-750 with C-100 shown above

### Machine Options - AUTOFEED

Catalog No.	Model No.	Description	Weight	
			lb.	kg.
<b>230V</b>				
44152	K-750 w/C-75	Machine with RIDGID PVC Drain Cleaning Gloves, AUTOFEED, Standard 3/4" (20 mm) Tool Set and: C-75, 75' x 3/4" (23 m x 20 mm) Cable	206	93,6
44157	K-750 w/C-100	Machine with RIDGID PVC Drain Cleaning Gloves, AUTOFEED, Standard 3/4" (20 mm) Tool Set, and: C-100, 100' x 3/4" (30 m x 20 mm) Cable	234	106,3
44162	K-750 w/C-27	Machine with RIDGID PVC Drain Cleaning Gloves, AUTOFEED, Standard 5/8" (16 mm) Tool Set, and: C-27, 75' x 5/8" (23 m x 16 mm) Cable	182	82,7
44147	K-750	230 V, 50 Hz Machine with RIDGID PVC Drain Cleaning Gloves, 3/4" Pigtail	104	47,3
<b>115V</b>				
45612	K-750	115 V, 50 Hz Machine with RIDGID PVC Drain Cleaning Gloves, 3/4" Pigtail	104	47,3

# DRAIN CLEANING

## Inner Core (IC) Cables



Good flexibility and more cleaning power to the cable end.

	Catalog No.	Model No.	Description	Weight	
				lb.	kg
5/8" (16 mm)	92460	C-25	25' IC Cable (7,6 m)	24	10,9
	92465	C-26	50' IC Cable (15,2 m)	43	19,5
	92470	C-27	75' IC Cable (23 m)	63	28,6
	43647	C-24	100' IC Cable (30,5 m)	84	38,1
3/4" (20 mm)	92475	C-28	25' IC Cable (7,6 m)	30	13,9
	92480	C-29	50' IC Cable (15,2 m)	60	27,2
	41212	C-75	75' IC Cable (23 m)	93	42,5
	41697	C-100	100' IC Cable (30,5 m)	122	55,3

## Hollow Core Cables

	Catalog No.	Model No.	Description	Weight	
				lb.	kg
5/8" (16 mm)	32737	C-27HC	75' HC Cable (23 m)	52 3/4	23,9
	58192	C-24HC	100' HC Cable (30,5 m)	70 1/2	32,1
3/4" (20 mm)	47427	C-75HC	75' HC Cable (23 m)	75	34,0
	47432	C-100HC	100' HC Cable (30,5 m)	100	45,5

## Leaders and Pig Tails

	Catalog No.	Model No.	Description	Weight	
				lb.	kg
	92555	T-458	5/8" (16 mm) x 2' (50 mm) Leader	2	0,85
	92560	T-468	3/4" (20 mm) x 2' (50 mm) Leader	2 3/4	1,25
	44122	—	5/8" (16 mm) Pigtail, 4 1/2" (114 mm) Long	2 1/2	1,13
	44117	—	3/4" (20 mm) Pigtail, 6" (150 mm) Long	3 1/2	1,59

## QUICK-CONNECT CABLE & TOOLS

Rotate pin one-half turn in either direction to quickly add cable or tools:

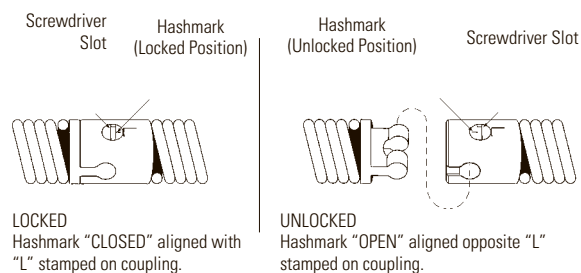





Coupling features stainless steel pin and spring; eliminates need for punches, stands, or expansion pins.







For C-24, C-25, C-26, C-27, C-28, C-29, C-75, C-100, C-27HC, C-24HC, C-75HC, and C-100HC.

## Tools and Replacement Blades – Fit 5/8" (16 mm) and 3/4" (20 mm) Cables

C-24, C-25, C-26, C-27, C-28, C-29, C-75, C-100, C-27HC, C-24HC, C-75HC and C-100HC

	Catalog No.	Model No.	Description	Replacement	
				Blade(s)	Holder
	92485	T-403	P-Trap Cutter, 3" (75 mm)	92835	92900
	92490	T-404	P-Trap Cutter, 3 1/2" (87 mm)	92840	92900
	92495	T-406	Spade Cutter, 1 3/4" (45 mm)	92850	92915
	92500	T-407	Retrieving Auger 2 5/16" (65 mm)	—	—
	92505	T-408	Sawtooth Cutter, 3" (75 mm)	92890	92915
	51762	T-409	H-D Bulb Auger, 1 3/4" (45 mm)	—	—
	92510	T-411	Double Cutter, 2" (50 mm)	92815	92905
	92515	T-412	Double Cutter, 2 1/2" (65 mm)	92820	92905
	92520	T-413	Double Cutter, 3" (75 mm)	92825	92910
	92525	T-414	Double Cutter, 4" (110 mm)	92830	92910
	92530	T-416	Double Cutter, 6" (150 mm)	92855	92910
		92535	T-432	3-Blade Cutter 2" (50 mm)	92860
92540		T-433	3-Blade Cutter 3" (75 mm)	92865	92895
92545		T-434	3-Blade Cutter 4" (110 mm)	92870	92895
92550		T-436	3-Blade Cutter 6" (150 mm)	92875	92895

## Accessories

	Catalog No.	Model No.	Description	Weight	
				lb.	kg
	43637	T-458	Drum Assembly w/5/8" (16 mm) Pigtail	33	15
	41982	T-468	Drum Assembly w/3/4" (20 mm) Pigtail	37 1/2	17,0
	43642	—	AUTOFEED Assembly	8	3,5
	41992	—	C-100IC Kit w/Tools, 3/4" (20 mm) x 100' (30,5 m)	—	—
49032	—	Front Guide Hose Assembly	3	1,3	
	46015	E-453	Allen Wrench	—	—
	41937	—	RIDGID Leather Drain Cleaning Gloves	1/2	0,2
	70032	—	RIDGID PVC Drain Cleaning Gloves	1/2	0,2
	59360	A-3	Tool Box	5	2,3
				oz.	g
	31487	A-7570	5/8" (16 mm) Repair Splicer	1 1/2	43
	92805	A-6582	5/8" (16 mm) Male Coupling	1	28
	92810	A-6583	5/8" (16 mm) Female Coupling	2	57
	31492	A-7571	3/4" (20 mm) Repair Splicer	2	57
	92880	B-6840	3/4" (20 mm) Male Coupling	1	28
	92885	B-6841	3/4" (20 mm) Female Coupling	2	57

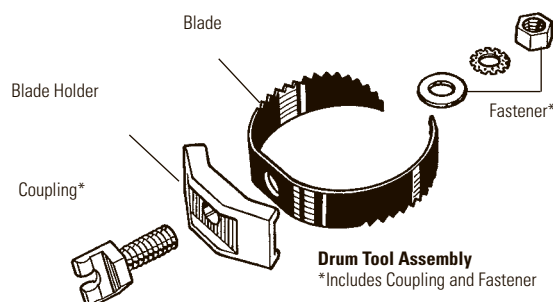

# DRAIN CLEANING

## K-7500 Drum Machine



### Standard Accessories

- T-406 – Spade Cutter.
- T-407 – Retrieving Auger.
- T-411 – 2" (50 mm) Double Cutter.
- T-413 – 3" (75 mm) Double Cutter.
- T-414B – 4" (110 mm) Double Cutter - (Blade only).
- T-416B – 6" (150 mm) Double Cutter - (Blade only).
- T-408 – Sawtooth Cutter.
- T-403 – 3" (75 mm) P-Trap Cutter.
- T-468 – 3/4" (20 mm) Flexible Leader.
- Tool Box, Hex Key, RIDGID PVC Drain Cleaning Gloves.

For 5/8" (16 mm) machine package (Catalog No. 61512), the T-468 Leader is replaced with the T-458 Leader and the 6" (150 mm) Double Cutter Blade is eliminated.

### For 3" (75 mm) to 10" (250 mm) Lines

- The performance, cable control, durability, and maneuverability demanded by professional users. Ideal for any tough job, such as roots – up to 250' (76 m).
- Recommend 5/8" (16 mm) cable for 3" (75 mm) to 6" (150 mm) drain lines up to 250' (76 m).
- Recommend 3/4" (20 mm) cable for 4" (110 mm) to 10" (250 mm) drain lines up to 250' (76 m).
- Cable spins at 200 RPM.
- Powerful, yet quiet, 600 W universal motor and gearbox bear down as cutter engages tough obstructions.
- Provides audible and visual signals to operator.
- Inner-drum and ball bearing distributor arm work with motor/gearbox system to reduce chance of cable flip-over inside the drum.
- Main and inner drums won't rust, split or dent – ever, and clean easily for professional appearance. Main drum holds up to 100' (30,5 m) of 3/4" (20 mm) cable or 125' (38 m) of 5/8" (16 mm) cable.
- Powerful AUTOFEED® mechanism has grease fittings and an open design for easy maintenance; advances and retrieves cable up to 22' (6,7 m) per minute.
- Two position stair climber eases transport and loading – eliminates extra cost for loading wheels.
- Narrow profile allows machine to fit through bathroom doors.
- Handles adjust to desired height to ensure balanced transport.
- Includes RIDGID® PVC drain cleaning gloves and operator's manual.

### Machine Options – Power Feed

Catalog No.	Model No.	Description	Weight	
			lb.	kg
220-240V				
61542	K-7500	Machine w/3/4" (20 mm) Pigtail and Standard Accessories	150	86,2
61522	K-7500	Machine w/5/8" (16 mm) Pigtail and Standard Accessories	149	67,8
61512	K-7500 w/C-24	Machine, Standard Accessories, and 5/8" (16 mm) x 100' (30,5 m) Inner Core Cable	233	106
61517	K-7500 w/C-100	Machine, Standard Accessories, and 3/4" (20 mm) x 100' (30,5 m) Inner Core Cable	272	123,7

# DRAIN CLEANING

## Cable Control & Performance – When Tool Engages Tough Obstructions

### Cable contracts towards inner drum.

- Provides additional strength.
- Further protection against cable flip over inside the drum.

Under high torque

Under normal operating conditions

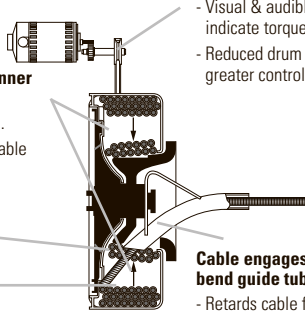

## Motor slows while power builds.

- Visual & audible signals indicate torque increase.
- Reduced drum speed provides greater control.

### Cable engages compound bend guide tube.

- Retards cable flip over inside the drum.

## Inner Core (IC) Cables

Good flexibility and more cleaning power to the cable end.

	Catalog No.	Model No.	Description	Weight	
				lb.	kg
5/8" (16 mm)	92460	C-25	25' IC Cable (7,6 m)	24	10,9
	92465	C-26	50' IC Cable (15,2 m)	43	19,5
	92470	C-27	75' IC Cable (22,9 m)	63	28,6
	43647	C-24	100' IC Cable (30,5 m)	84	38,1
3/4" (20 mm)	92475	C-28	25' IC Cable (7,6 m)	30	13,9
	92480	C-29	50' IC Cable (15,2 m)	60	27,2
	41212	C-75	75' IC Cable (22,9 m)	93	42,5
	41697	C-100	100' IC Cable (30,5 m)	122	55,3

## Hollow Core Cables

	Catalog No.	Model No.	Description	Weight	
				lb.	kg
5/8" (16 mm)	32737	C-27HC	75' HC Cable (23 m)	52 3/4	23,9
	58192	C-24HC	100' HC Cable (30,5 m)	70 1/2	32,1
3/4" (20 mm)	47427	C-75HC	75' HC Cable (23 m)	75	34,0
	47432	C-100HC	100' HC Cable (30,5 m)	100	45,5

## Leaders and Pig Tails

	Catalog No.	Model No.	Description	Weight	
				lb.	kg
	92555	T-458	5/8" (16 mm) x 2' (50 mm) Leader	2	0,85
	92560	T-468	3/4" (20 mm) x 2' (50 mm) Leader	2 3/4	1,25
	44122	—	5/8" (16 mm) Pigtail, 4 1/2" (114 mm) Long	2 1/2	1,13
	44117	—	3/4" (20 mm) Pigtail, 6" (150 mm) Long	3 1/2	1,59

## Tools and Replacement Blades – Fit 5/8" (16 mm) and 3/4" (20 mm) Cables

C-24, C-25, C-26, C-27, C-28, C-29, C-75, C-100, C-27HC, C-24HC, C-75HC and C-100HC

	Catalog No.	Model No.	Description	Replacement	
				Blade(s)	Holder
	92485	T-403	P-Trap Cutter, 3" (75 mm)	92835	92900
	92490	T-404	P-Trap Cutter, 3 1/2" (87 mm)	92840	92900
	92495	T-406	Spade Cutter, 1 3/4" (45 mm)	92850	92915
	92500	T-407	Retrieving Auger 2 3/16" (65 mm)	—	—
	92505	T-408	Sawtooth Cutter, 3" (75 mm)	92890	92915
	51762	T-409	H-D Bulb Auger, 1 3/4" (45 mm)	—	—
	92510	T-411	Double Cutter, 2" (50 mm)	92815	92905
	92515	T-412	Double Cutter, 2 1/2" (65 mm)	92820	92905
	92520	T-413	Double Cutter, 3" (75 mm)	92825	92910
	92525	T-414	Double Cutter, 4" (110 mm)	92830	92910
	92530	T-416	Double Cutter, 6" (150 mm)	92855	92910
	92535	T-432	3-Blade Cutter 2" (50 mm)	92860	92895
	92540	T-433	3-Blade Cutter 3" (75 mm)	92865	92895
	92545	T-434	3-Blade Cutter 4" (110 mm)	92870	92895
	92550	T-436	3-Blade Cutter 6" (150 mm)	92875	92895

## Accessories

	Catalog No.	Model No.	Description	Weight	
				lb.	kg
	60042	A-7534D	Drum Assembly w/3/4" (20 mm) Pigtail	31	14
	61107	A-7558D	Drum Assembly w/5/8" (16 mm) Pigtail	30	13,6
	60047	A-75DR	Drum Only	20	9
	60032	A-75PF	AUTOFEED Assembly	10	4,5
	60037	—	AUTOFEED Spacers	—	—
	41992	—	C-100 IC Kit w/Tools 3/4" (20 mm) x 100' (30,5 m)	—	—
	49032	—	Front Guide Hose Assembly	3	1,3
	41937	—	RIDGID Leather Drain Cleaning Gloves	1/2	0,2
	70032	—	RIDGID PVC Drain Cleaning Gloves	1/2	0,2
	59360	A-3	Tool Box	5	2,3
				oz.	g
	31487	A-7570	5/8" (16 mm) Repair Splicer	1 1/2	43
	92805	A-6582	5/8" (16 mm) Male Coupling	1	28
	92810	A-6583	5/8" (16 mm) Female Coupling	2	57
	31492	A-7571	3/4" (20 mm) Repair Splicer	2	57
	92880	B-6840	3/4" (20 mm) Male Coupling	1	28
	92885	B-6841	3/4" (20 mm) Female Coupling	2	57

## QUICK-CONNECT CABLE & TOOLS

Rotate pin one-half turn in either direction to quickly add cable or tools: Screwdriver Slot

Screwdriver Slot

Hashmark (Locked Position)



Hashmark (Unlocked Position)

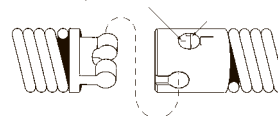

LOCKED Hashmark "CLOSED" aligned with "L" stamped on coupling.

Coupling features stainless steel pin and spring; eliminates need for punches, stands, or expansion pins.

UNLOCKED Hashmark "OPEN" aligned opposite "L" stamped on coupling.